

PX349

Splitter

DMX-RDM

User manual



Table of Contents

1 Description.....	3
2 Safety conditions.....	4
3 Connectors and control elements.....	5
4 DMX signal connection.....	6
5 Information communicated by LED indicator.....	8
6 Connection scheme.....	9
7 Dimensions.....	10
8 Technical data.....	11

Manufacturer reserves the right to make modifications in order to improve device operation.

PXM Marek Żupnik sp.k.
Podłęże 654
32-003 Podłęże
BDO register number 000005972

tel. +48 12 385 83 06
mail: info@pxm.pl
www.pxm.pl

Rev.1-1
05.02.2019

1 Description

DMX signal splitter enables branching in complex DMX installations. The combination of a large number of receivers in series can be troublesome, therefore it was possible to create branching DMX tracks using a splitter.

The PX349 supports the RDM protocol, which allows bidirectional packet transmission.

With PX349, it possible to split the DMX input signal into four independent branches. The individual outputs are galvanically isolated from input and between each other. The output signals are appropriately reinforces, which guarantees correct operation of the entire installation.

Splitter DMX-RDM is manufactured in a housing adapted for mounting on standard DIN 35mm rails.

2 Safety conditions

Splitter PX349 is a device powered with safe voltage 12 – 24V DC, however, during its installation and use the following rules must be strictly observed:

1. The device may be connected to 12 – 24V DC (stabilized voltage) with current-carrying capacity compatible with technical data.
2. All the conductors should be protected against mechanical and thermal damage.
3. In the event of damaging any conductor, it should be replaced with a conductor of the same technical data.
4. Only use a shielded cable for connecting the DMX signal.
5. All repairs and connection of outputs or DMX signal can only be made with cut off power supply.
6. PX349 should be strictly protected against contact with water and other liquids.
7. All sudden shocks, particularly dropping, should be avoided.
8. Do not connect the device with a damaged (broken) housing to the power supply.
9. The device cannot be turned on in places with humidity exceeding 90%.
10. The device cannot be used in places with temperature lower than +2°C or higher than +40°C.
11. Clean with damp cloth only – splitter should be cut off from power supply.

3 Connectors and control elements

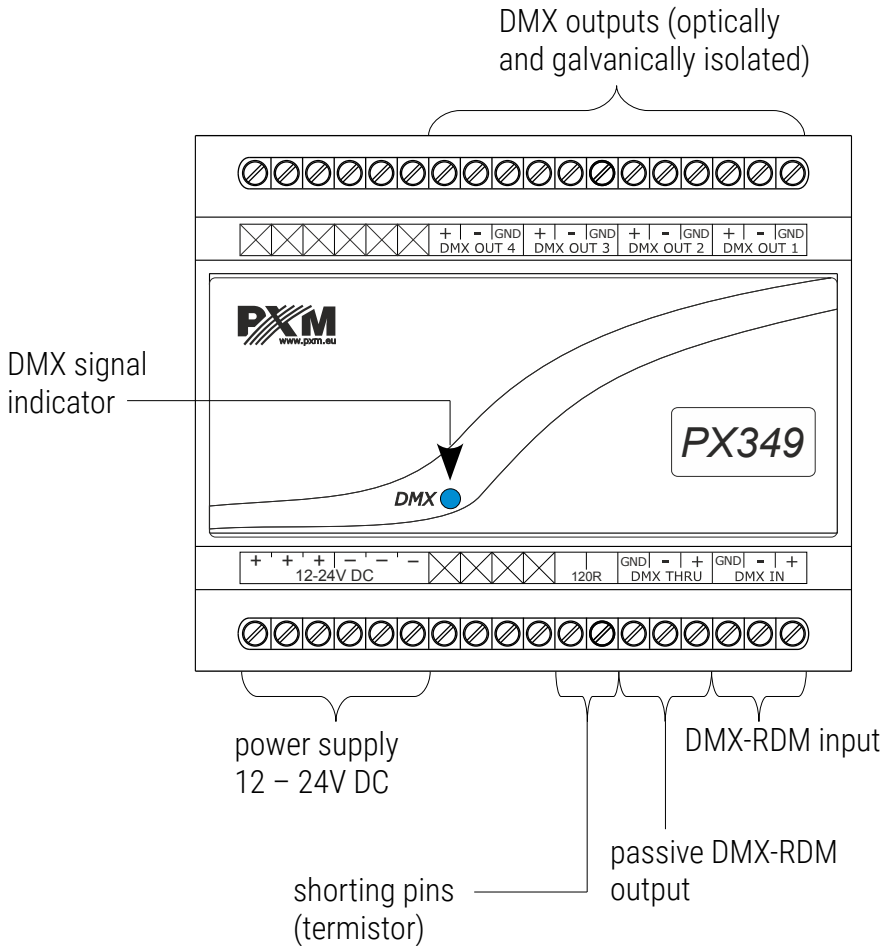

4 DMX signal connection

PX349 have to be connected to DMX line in serial mode, with no branches on DMX control cable. That mean that DMX line, from the signal source, must be connected to **DMX IN** pins of PX349 and later, directly from **DMX THRU** pins to the next device in DMX chain.

If the PX349 is the last DMX chain receiver (there is no connected receiver for the **DMX THRU** output), it is necessary to shorten **120R** pins – the bridge on these pins will act as a terminator (120 Ohm resistor).

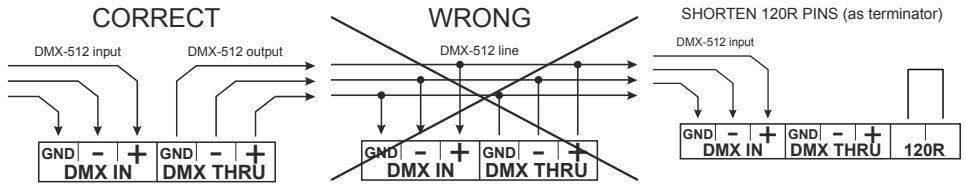

Each of the four splitter outputs is treated as the start of a new DMX line. A maximum of 32 devices can be connected with the DMX line, with the length up to 500 meters. In the last device of each DMX output line it is necessary to connect the terminator.

NOTE! A maximum of 4 splitters can be connected in a cascade (the scheme is on the next page).

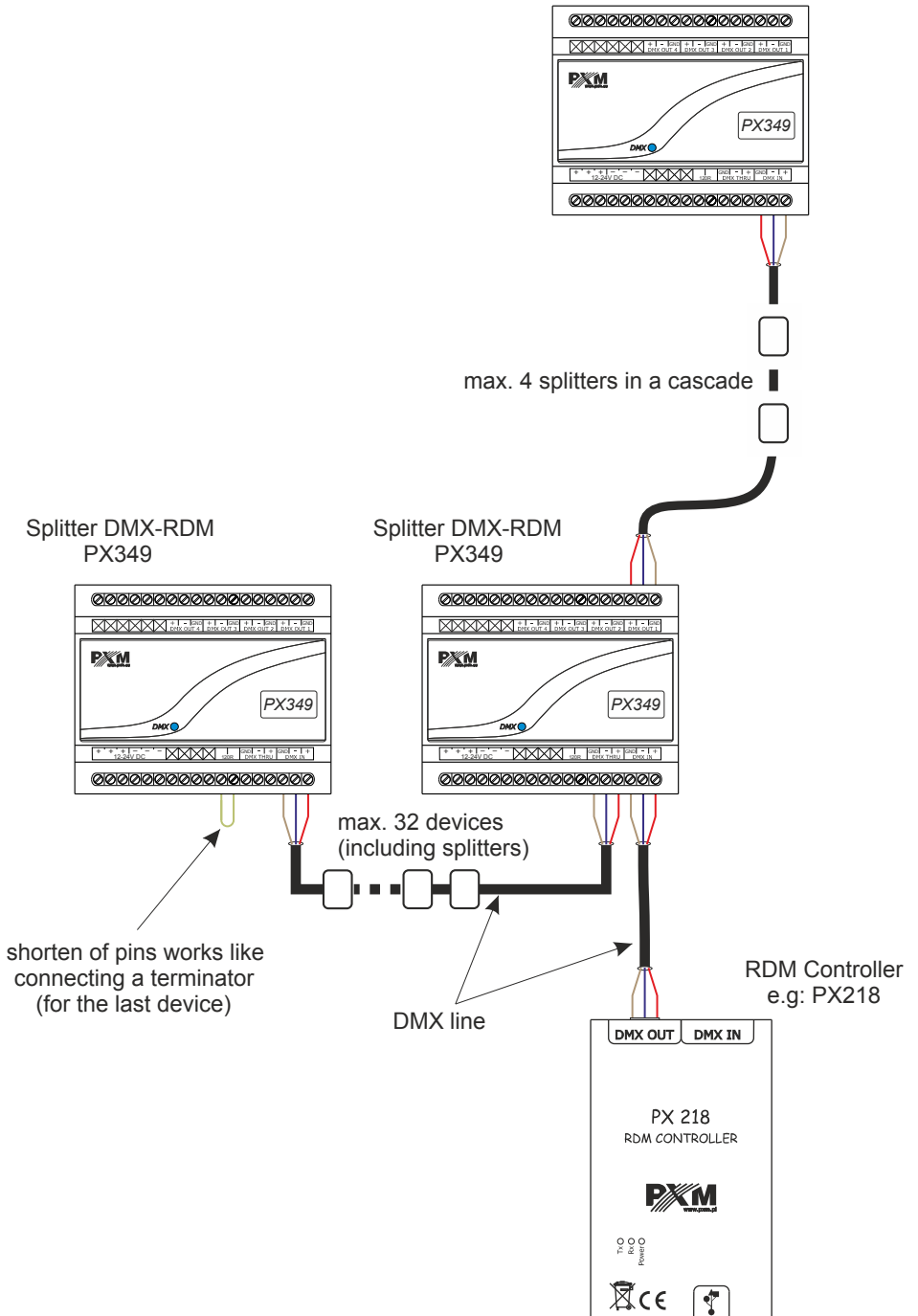

5 Information communicated by LED indicator

On the device housing there is a diode indicating the operating status of the device.

Action	Function
blinks few times orange and blue	power connection
blinking in blue	DMX signal transmission
blinking in orange	sending the RDM package
constantly lights up blue	the device does not receive the DMX signal

6 Connection scheme

a) connection of the RDM controller and three drivers to two DMX outputs

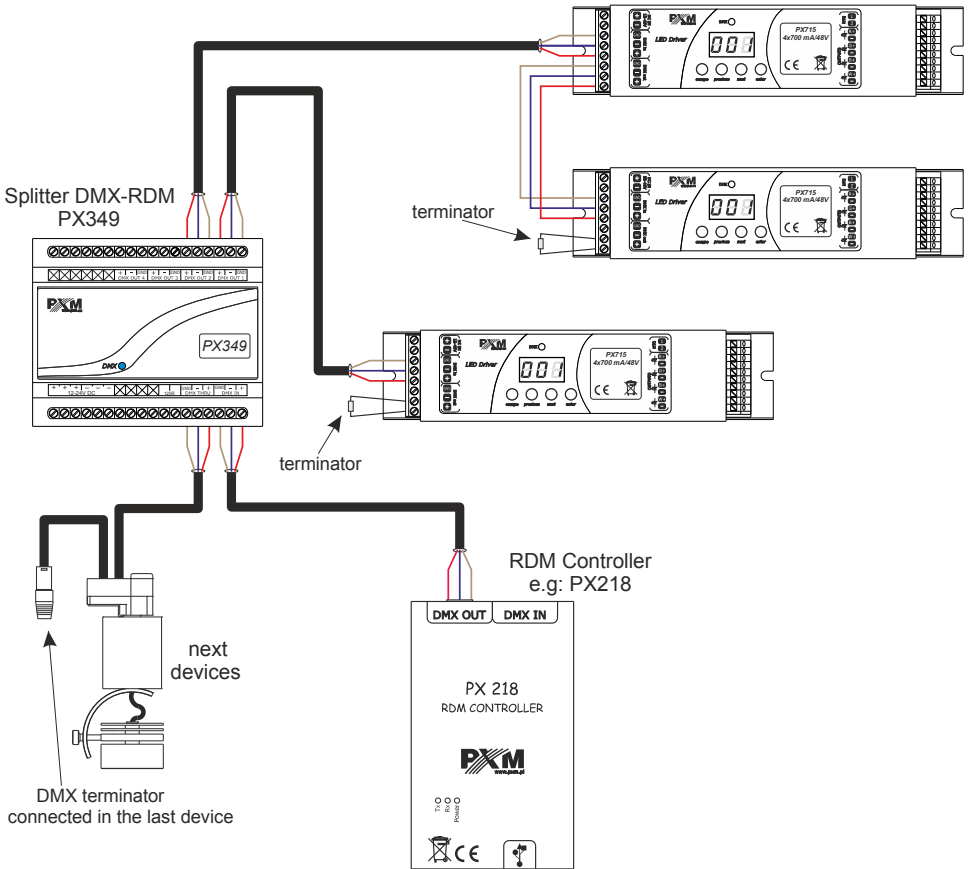

b) shorting of 120R pins – if the splitter is the last device and no receiver is connected to the *DMX THRU* output, the bridge on these pins acts as a terminator

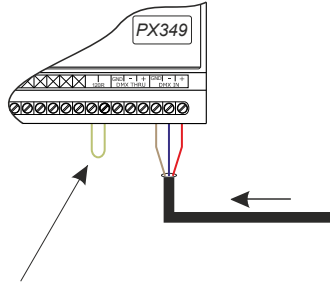

shorting of 120R pins,
(works like connecting a terminator,
if the splitter is the last device)

7 Dimensions

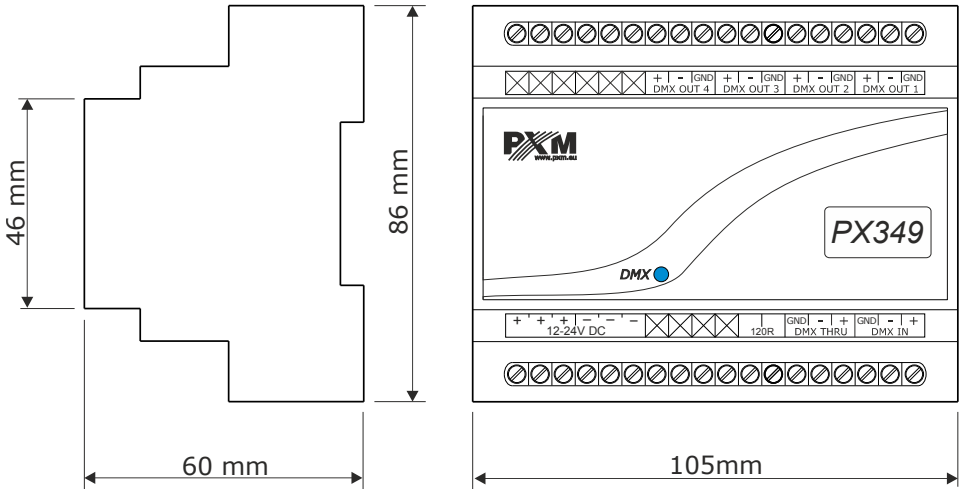

8 Technical data

type	PX349
power supply	12 – 24V DC
DMX channels	512
number of DMX inputs	1
number of DMX outputs	4
RDM protocol support	yes
optical isolation of DMX lines	yes
built-in terminator	yes (shorting of two 120R pins)
breakdown voltage of the I / O isolation	>1000V
power consumption	max. 7W
weight	0.2kg
dimensions	width: 105mm (6 DIN modules) height: 86mm depth: 60mm

DECLARATION OF CONFORMITY

PXM Marek Żupnik spółka komandytowa
Podłęże 654, 32-003 Podłęże

we declare that our product:

Product name: Splitter DMX-RDM

Product code: PX349

meets the requirements of the following standards, as well as harmonised standards:

PN-EN IEC 63000:2019-01	EN IEC 63000:2018
PN-EN 61000-4-2:2011	EN 61000-4-2:2009
PN-EN IEC 61000-6-1:2019-03	EN IEC 61000-6-1:2019
PN-EN 61000-6-3:2008	EN 61000-6-3:2007

and meets the essential requirements of the following directives:

2011/65/UE **DIRECTIVE OF THE EUROPEAN PARLIAMENT AND OF THE COUNCIL** of 8 June 2011 on the restriction of the use of certain hazardous substances in electrical and electronic equipment
Text with EEA relevance.

2014/30/UE **DIRECTIVE OF THE EUROPEAN PARLIAMENT AND OF THE COUNCIL** of 26 February 2014 on the harmonisation of the laws of the Member States relating to electromagnetic compatibility (recast)
Text with EEA relevance.

Marek Żupnik spółka komandytowa
32-003 Podłęże, Podłęże 654
NIP 677-002-54-53



mgr inż. Marek Żupnik.